

INTENDED USE

Accessory used with clamped shoes to give the Line Stop function with 3 mm gap.

INSTRUCTION FOR USE

Use 2x M12 bolts in the pre-drilled holes to fasten the item to a clamped shoe.

For Adjustable Clamped shoes, use the pre-drilled holes in the baseplate of the shoe. There are two different bolt hole patterns on the part, where one will give 3 mm gap if you only have the channel, and the other one will give you an extra 6 mm (CH100)/8 mm (CH 125) offset to provide 3 mm gap when accompanied by the Bolted Line Guide/Hold Down part.

For shoes without the pre-drilled holes, use either hole pattern and drill 2 x 13 mm holes in the baseplate of the shoe with the proper distance to give you your desired Line Stop gap.

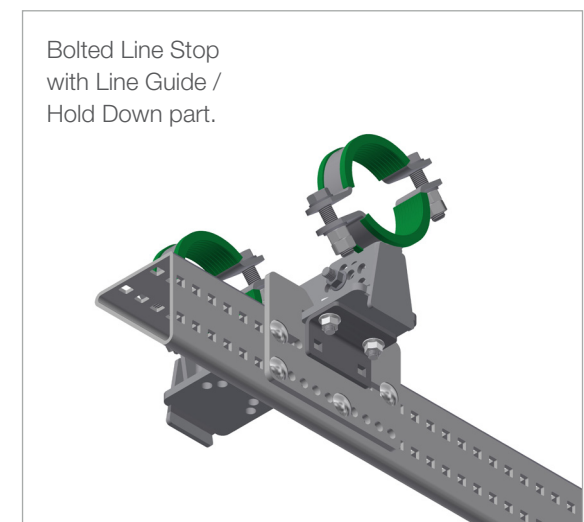
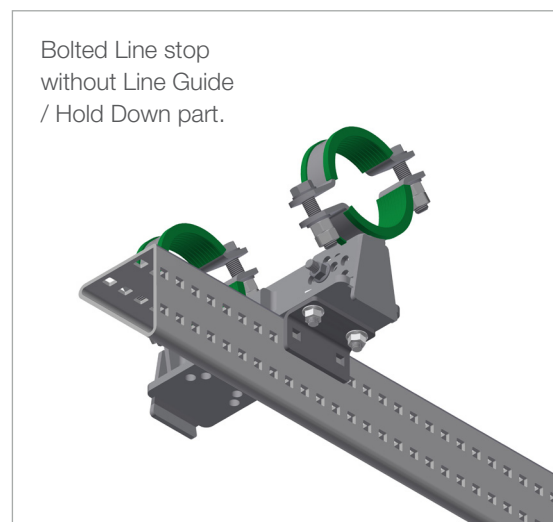
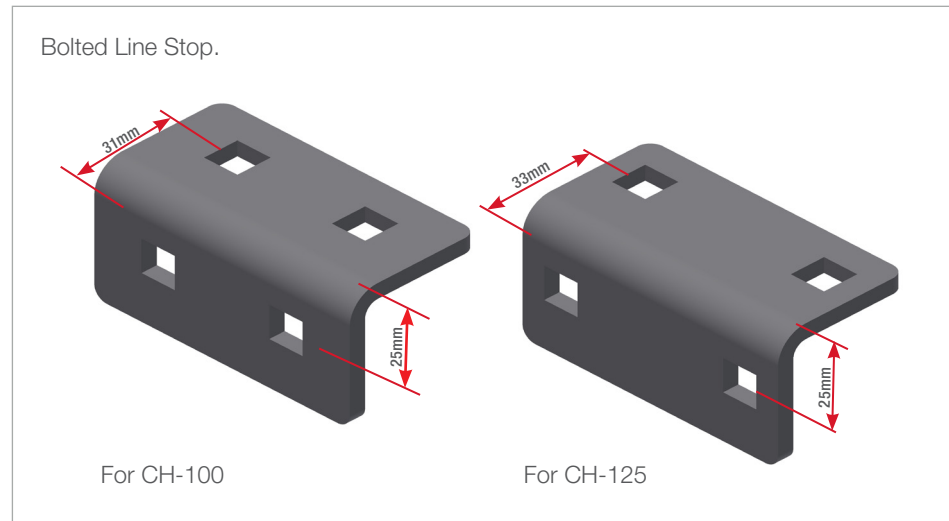

User Guide for Bolts:
Recommended Torque